

2021 International Swimming Pool and Spa Code and Amendments

ARTICLE VI. - INTERNATIONAL POOL AND SPA CODE

DIVISION 1. - GENERAL

Sec. 5-276. - International Pool and Spa Code—Adopted.

The International Pool and Spa Code, 2021 Edition as published by the International Code Council, Inc., a copy of which is on file in the office of the city secretary, as amended by [section 5-277](#), administered and enforced by the office of the building official is hereby adopted by reference and designated as the pool and spa code of the City of Hurst as though such code were copied at length in this article.

Sec. 5-277. - Same—Deletions and amendments.

PART 1 – SCOPE AND APPLICATION; SECTION 101 SCOPE AND GENERAL REQUIREMENTS

Section 101.1 Title.

Add City of Hurst in lieu of NAME OF JURISDICTION

PART 2 – ADMINISTRATION AND ENFORCEMENT; SECTION 103 CODE COMPLIANCE AGENCY

Section 103.1. Creation of Agency. Change to read as follows:

The Building Inspections Department is hereby created and the official in charge thereof shall be known as the Building Official. The function of the agency shall be the implementation, administration, interpretation, and enforcement of the provisions of this code and to adopt policies and procedures in order to clarify the application of its provisions.

Section 102.9; Change to read as follows:

Section 102.9 Other laws. The provisions of this code shall not be deemed to nullify any provisions of local, state or federal law, to include but not limited to:

1. Texas Department of State Health Services (TDSHS); *Standards for Public Pools and Spas*; §285.181 through §285.208, (TDSHS rules do not apply to pools serving one- and two-family dwellings or townhouses).
2. *Texas Department of Licensing and Regulation (TDLR); 2012 Texas Accessibility Standards (TAS)*, TAS provide the scoping and technical requirements for accessibility for Swimming Pool, wading pools and spas and shall comply with 2012 TAS, *Section 242*. (TAS rules do not apply to pools serving one- and two-family dwellings or townhouses).

Exception: Elements regulated under Texas Department of Licensing and Regulation (TDLR) and built in accordance with TDLR approved plans, including any variances or waivers granted by the TDLR, shall be deemed to be in compliance with the requirements of this Chapter.

Section 106.1 Add new section as follows:

106.1.1 Pools in Flood Hazard Areas. Pools requesting to be located in flood hazard areas will submit a Flood Development Permit, provided by the city, along with the construction documents.

Section 108 Fees; Section 108.2 Schedule of Fees; add subsection 108.2.1 to read as follows:

108.2.1 The fees for all swimming pool, hot tubs, or spa work shall be set by the City Manager and reviewed by City Council from time to time.

Section 113 Violations; Change sections 113.2, 113.3, and 113.4 to read as follows:

113.2. Notice of violation. The code official is authorized to serve a notice of violation or order to the person responsible for the erection, installation, alteration, extension, repair, removal or demolition of work in violation of the provisions of this code, or in violation of a detail statement or the approved construction documents thereunder, or in violation of a permit or certificate issued under the provisions of this code. Such order shall direct the discontinuance of the illegal action or condition and the abatement of the violation.

113.3 Prosecution of violation. Delete section.

113.4 Violation penalties. Any person who violates a provision of this code, or fails to comply with any of the requirements herein or erect, install, alter or repair a pool, hot tub, or spa in violation of the approved construction documents or directive of the code official, or of a permit or certificate issued under the provisions of this code, shall be guilty of a misdemeanor and upon conviction thereof shall be fined in a sum not to exceed two thousand dollars (\$2,000.00). Each day that a violation continues shall be deemed a separate offense.

Section 111 Means of Appeal. Change Section 111.1 to read as follows:

Section 111.1 *Application for appeal.* Any person shall have the right to appeal a decision of the code official to the board of appeals established by ordinance. The board shall be governed by the enabling ordinance.

Section 305 BARRIER REQUIREMENTS; Add subsection 305.2.7.1; to read as follows:

305.2.7.1 Chain link fencing prohibited. Chain link fencing is not permitted as a barrier in public pools built after January 1, 1994.

Section 305.4 structure wall as a barrier; Changes as follows:

305.4 Structure wall as a barrier. Where a wall of a dwelling or structure of a one- and two-family dwelling or townhouse or its accessory structure serves as part of a barrier and where doors or windows provide direct access to the pool or spa through that wall, one of the following shall be required:

1. Remainder Unchanged
2. Remainder Unchanged
3. Remainder Unchanged
4. Remainder unchanged
5. Delete
6. Remainder unchanged

Section 305.6; Change to read as follows:

305.6 Natural barriers used in a one- and two-family dwelling or townhouse. In the case where the pool or spa area abuts the edge of a lake or other natural body of water, public access is not permitted or allowed along the shoreline, and required barriers extend to and beyond the water's edge a minimum of eighteen (18) inches, a barrier is not required between the natural body of water shoreline and the pool or spa.

Section 307.1.4 Accessibility; Add exception to Section to 307.1.4 as follows:

Exception: Components of projects regulated by and registered with Architectural Barriers Division of Texas Department of Licensing and Regulation shall be deemed to be in compliance with the requirements of this chapter.

Section 307.2.2.2; add subsection to read as follows:

Section 307.2.2.2. Adjacency to Structural Foundation. A minimum distance of five feet (5') shall be maintained from the water's edge to the nearest foundation, footing, or retaining wall.

Exception:

A sealed engineered design drawing of the proposed new structure shall be submitted for approval.

Section 310; Change to read as follows:

310.1 General. Suction entrapment avoidance for pools and spas shall be provided in accordance with APSP 7 (ANSI/PHTA/ICC 7) or for public swimming pools in accordance with State of Texas Rules for Public Swimming Pools and Spas, Title 25 TAC Chapter 265 Subchapter L, Rule §265.190.

[Remainder unchanged]

Section 402.12; Change to read as follows:

402.12 Water envelopes. The minimum diving water envelopes shall be in accordance with ~~Table 402.12~~ Texas department of State Health services, Administrative Code Title 25, Chapter 265, Section 186 (e) and Figure: 25 TAC 256.186 (e) (6). (Delete Table 402.12 and Figure 402.12)

ADD: Figure: 25 TAC §265.186 (e) (6)

Maximum Diving Board Height Over Water	¾ Meter	1 Meter	3 Meters
Max. Diving Board Length	12 ft.	16 ft.	16 ft.
Minimum Diving Board Overhang	2 ft. 6 in.	5 ft.	5 ft.
D1 Minimum	8 ft. 6 in.	11 ft. 2 in.	12 ft. 2 in.
D2 Minimum	9 ft.	10 ft. 10 in.	11 ft. 10 in.

D3 Minimum	4 ft.	6 ft.	6 ft.
L1 Minimum	4 ft.	5 ft.	5 ft.
L2 Minimum	12 ft.	16 ft. 5 in.	19 ft. 9 in.
L3 Minimum	14 ft. 10 in.	13 ft. 2 in.	13 ft. 11 in.
L4 Minimum	30 ft. 10 in.	34 ft. 7 in.	38 ft. 8 in.
L5 Minimum	8 ft.	10 ft.	13 ft.
H Minimum	16 ft.	16 ft.	16 ft.
From Plumbet to Pool Wall at Side	9 ft.	10 ft.	11 ft. 6 in.
From Plumbet to Adjacent Plumbet	10 ft.	10 ft.	10 ft.

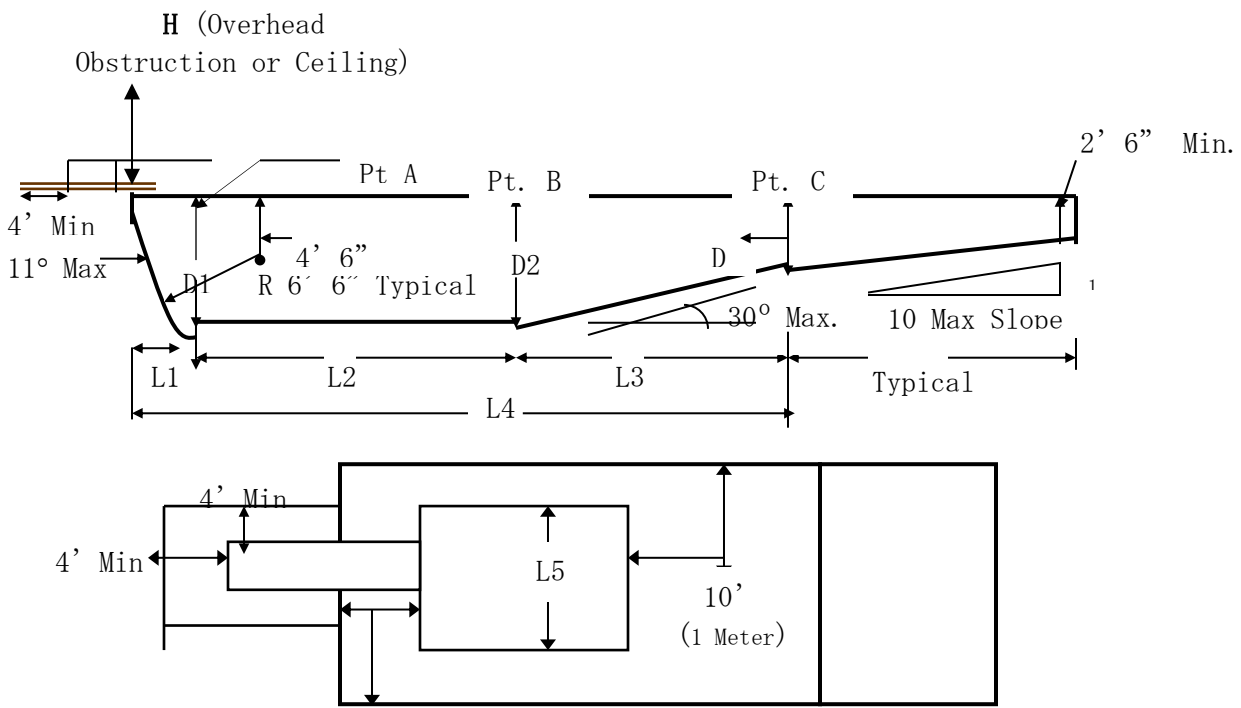

Section 411.2.1 & 411.2.2; Change to read as follows:

411.2.1 Tread dimensions and area. Treads shall have a minimum unobstructed horizontal depth (i.e., horizontal run) of 12 inches and a minimum width of 20 inches. ~~not be less than 24 inches (607mm) at the leading edge. Treads shall have an unobstructed surface area of not less than 240 square inches (154838mm²) and an unobstructed horizontal depth of not less than 10 inches (254 mm) at the center line.~~

411.2.2 Risers. Risers for steps shall have a maximum uniform height of 10 inches, with the bottom riser height allowed to taper to zero ~~except for the bottom riser, shall have a uniform height of not greater than 12 inches (305 mm) measured at the center line. The bottom riser height is allowed to vary to the floor.~~

Section 411.5.1 & 411.5.2; Change to read as follows:

411.5.1 Swimouts. Swimouts, located in either the deep or shallow area of a pool, shall comply with all of the following:

1. Unchanged
2. Unchanged

3. Unchanged
4. The leading edge shall be visibly set apart and provided with a horizontal solid or broken stripe at least 1 inch wide on the top surface along the front leading edge of each step. This stripe shall be plainly visible to persons on the pool deck. The stripe shall be a contrasting color to the background on which it is applied, and the color shall be permanent in nature and shall be a slip-resistant surface.

411.5.2 Underwater seats and benches. Underwater seats and benches, whether used alone or in conjunction with pool stairs, shall comply with all of the following:

1. Unchanged
2. Unchanged
3. Unchanged
4. Unchanged
5. The leading edge shall be visually set apart and provided with a horizontal solid or broken stripe at least 1 inch wide on the top surface along the front leading edge of each step. This stripe shall be plainly visible to persons on the pool deck. The stripe shall be a contrasting color to the background on which it is applied, and the color shall be permanent in nature and shall be a slip-resistant surface.
6. Unchanged
7. Unchanged

Section 610.5.1; Change to read:

610.5.1 Uniform height of 9-10 inches. Except for the bottom riser, risers at the centerline shall have a maximum uniform height of 9-10 inches (229-254 mm). The bottom riser height shall be permitted to vary from the other risers.

Section 804 Diving Water Envelopes; Change to read as follows:

Section 804.1 General. The minimum diving water envelopes shall be in accordance with Table 804.1 and Figure 804.1, or the manufacturer's specifications, whichever is greater. Negative construction tolerances shall not be applied to the dimensions of the minimum diving water envelopes given in Table 804.1.

Sec. 5-278 – 5 293 Reserved.